



## Clarius® PLUS

Infrared & White Light LED Illuminators

SECL-IR850-DC-S	SECL-WL928-DC-S
SECL-IR850-DC-M	SECL-WL2300-DC-M
SECL-IR850-DC-L	SECL-WL2784-DC-L
SECL-IR850-DC-XL	SECL-WL3712-DC-XL
SECL-IR850-POE-S	SECL-WL928-POE-S
SECL-IR850-POEPL-M	SECL-WL1856-POEPL-M
SECL-IR940-DC-S	
SECL-IR940-DC-M	
SECL-IR940-DC-L	
SECL-IR940-DC-XL	
SECL-IR940-POE-S	
SECL-IR940-POEPL-M	

Quick Installation Guide

### SPECIFICATION

Electronics	High efficiency surface mount high power LEDs with advanced current limited integral control circuitry
Beam Angles	10°, 30°, 60° & 95°
Lens/Beam Pattern	The illuminator should be matched to the scene and the camera lens focal length
Wavelength	850nm and visible white light 940nm and visible white light
Expected Life	10 years
Consumption	SECL-IRxxx-xx-S/SECL-WLxxx-xx-S 15W SECL-IRxxx-xx-M/SECL-WLxxx-xx-M 26W SECL-IRxxx-xx-L/SECL-WLxxx-xx-L 39W SECL-IRxxx-xx-XL/SECL-WLxxx-xx-XL 52W
Input Voltage	12-32V DC or 24V AC 50-60 Hz
Operating Temp	-50° to 50° (-58° to 122°F)
Environmental	IP66. Suitable for indoor and outdoor use
Construction	Robust high quality aluminium extrusion
Front Window	Polycarbonate high transmittance protection (vandal-proof) with CleanLITE® technology
Dimensions	SECL-IRxxx-xx-S/SECL-WLxxx-xx-S 68 x 110 x 78mm SECL-IRxxx-xx-M/SECL-WLxxx-xx-M 114 x 110 x 78mm SECL-IRxxx-xx-L/SECL-WLxxx-xx-L 161 x 110 x 78mm SECL-IRxxx-xx-XL/SECL-WLxxx-xx-XL 213 x 110 x 78mm
Weight	SECL-IRxxx-xx-S/SECL-WLxxx-xx-S 750g (1.6lbs) SECL-IRxxx-xx-M/SECL-WLxxx-xx-M 1.05kg (2.3lbs) SECL-IRxxx-xx-L/SECL-WLxxx-xx-L 1.35kg (3lbs) SECL-IRxxx-xx-XL/SECL-WLxxx-xx-XL 1.75kg (3.9lbs)
Power Cable	3m (9ft). Other lengths available to order
Mount	Black power coated stainless steel wall mount. Adjustable via M6 Allen Key (included)

### DESCRIPTION

A complete range in Infra-Red and White-Light illuminators for CCTV, the visible and Invisible range feature state of the art technology and installation friendly design.

- Energy efficient, low voltage operation for quick and easy installation
- Dual Core® LED technology with advanced electronic control circuitry deliver improved thermal management, long life and low cost of ownership.
- CleanLITE® self cleaning lens coating technology
- Semi covert, covert and visible White-Light versions
- Built in photo cell
- Easy integration with day/night cameras with relay contacts indicating if the built in photo cell has activated the illuminator
- Remote telemetry input
- Easy access to power and photo cell adjust
- Pressure equalisation vent prevents thermal expansion and pressure cycling
- Interchangeable lens diffuse technology



### INSTALLATION

Note:

- Installation should be done by skilled personnel or under supervision of such personnel
- The illuminator is low voltage 12-32V DC or 24V AC.
- Only to be installed in restricted Access Areas.
- Terminal block not included. Installation may require advice from a qualified person.

Optimum results are achieved by setting up at night and viewing the results on a monitor.

1. Attach the illuminator mount to pan/tilt unit, wall or camera housing. Using stainless steel fixings suitable for the relevant application.
2. Connect the lamp to a suitable (SELV) low voltage supply. Ensure that the polarity is correct.
3. Commission the mains supply, camera and monitoring equipment.
4. Select the diffuser angle sheet required from the Clarius box (if required). To position the required diffuser sheet, insert the tool included in the slot at the bottom of the cover and prise upwards slowly. Repeat at opposite end and carefully remove cover. Remove backing sheet from the two adhesive discs and secure required diffuser in position. Finally firmly clip the lens cover back into place.



5. Adjust the pan angle of the illuminator to match the camera field of view.
6. Adjust the vertical alignment by loosening the side bolts (one on each side of the main body) to maximise the results.
7. Tilt the lamp downwards until the rear part if the required field of view is saturated with light, as viewed on the monitor.
8. SLOWLY and GRADUALLY tilt the lamp upwards until the for part of the required field of view is illuminated correctly on the monitor.

## POWER AND CONTROL CABLE CONNECTIONS

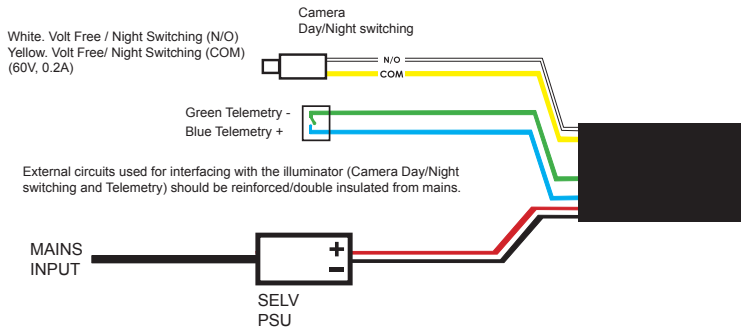

Use suitable IP66 rated enclosure and terminal block for connection conforming to EN60998-2-1 or EN60998-2-2

### Recommended PSU

SECL-IRxxx-xx-S/SECL-IRxxx-xx-M , SECL-WLxxx-xx-S/SECL-WLxxx-xx-M : **24V 30W** (SECL-PSU-30W)  
 SECL-IRxxx-xx-L/SECL-IRxxx-xx-XL , SECL-WLxxx-xx-L/SECL-WLxxx-xx-XL : **24V 60W** (SECL-PSU-60W)

Use only with Class 2 power supply.

SELV Power supply should be approved to relevant EN Safety standards.  
 SELV Power supply should be used with devices to protect against short circuits and overload.

### Remote Switching

The Illuminator may be activated remotely by a volt-free contact latched across the telemetry wires (see Diagram above).

### Photocell following contact

Volt-free relay contact-normally open (day) to normally closed (night). See diagram above.

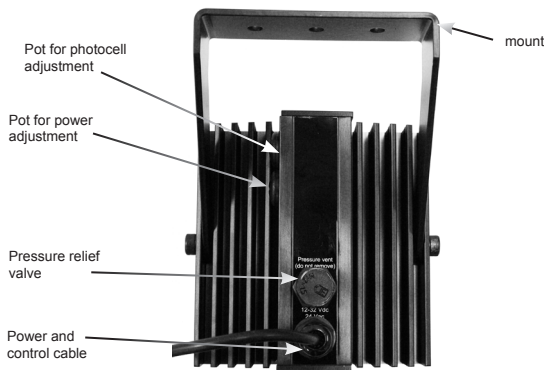

## CERTIFICATIONS

This product complies with the European Directive 2014/30/EU Electromagnetic Compatibility and 2014/35/EU Low Voltage Directive by meeting the following standards:

CE-EMC	EN 61547 EN 55015 EN 62493 EN 50130-4	(Lighting-Immunity) (Lighting-Emission) (Lighting -EMF) (Alarm-EMC)
CE-LVD	EN 60598-1 EN 60598-2-1	(Luminaires-General) (Luminaires)
Safety	EN 62471 Risk group 2	(LED safety)
Environmental	IEC/EN 60529 EN50130-5	IP66 (Alarm-environmental)
USA	FCC, Class B	
AUS	RCM (AS/NZS CISPR 22 Class B)	
RoHS:	Restriction of Hazardous Substances European directive 202/95/EC	
Certifications		
WEEE:	Waste Electrical & Electronic Equipment European directive 202/96/EC 	

This symbol on the product means that the electrical and/or electronic equipment to which it relates should be disposed of at the end of life separately from domestic household waste.

There are separate collection systems for recycling in the EU. For more information please contact the Local Authority or supplier of the product.

## Power Adjust

To adjust the power, first unscrew the sealing cap then adjust the power potentiometer clockwise to increase the power and counter clockwise to turn it down. The unit is factory set to maximum output.

## Photocell

The photocell is designed to automatically switch the lamps on at dusk and turn off at dawn. A high degree of hysteresis is incorporated to void on/off switching in marginal conditions. The unit is factory set at approximately 30 Lux On and 70 Lux Off, but can be adjusted.

## Photocell Sensitivity

To adjust the photocell sensitivity first remove the sealing cap, then adjust the potentiometer to turn the lamp on when lighting conditions are lighter or darker. Adjust the counter clockwise to make the lamp turn on when it is lighted and clockwise when it's darker.

## Disabling the photocell

To disable the photocell, adjust the sensitivity fully counter clockwise. This will make the lamp turn on at all times.

### Safety Warning

- When the lamp is running, it is hot to touch. before touching switch off the illuminator and allow to cool for a minimum of 10 minutes.
- The illuminator should be positioned so that prolonged staring into the illuminator at a distance closed than 1m is not expected.
- The light source of this illuminator is not replaceable, when the light source reaches its end of life the whole illuminator should be replaced.
- If the flexible power cord of the illuminator is damaged it should be exclusively replaced by an authorised service agent.
- This equipment is not suitable for use in locations where children are likely to be present.

## PoE Models

The Clarius PoE/PoE+ series illuminators are powered by Power over Ethernet (PoE) via a network cable connector to a PoE IEEE802af/IEEE802at compliant switch.

The power consumption of the illuminators comply with PoE IEEE802af and IEEE802at.

These illuminators are not supplied with a power cord. Instead, they are supplied with a 2.5m (8') long network cable. At the end of the network cable is a female RJ45 Cat5e compliant connector with an IP68 rated cover.

The IP68 rated cover is supplied with the illuminator. Follow the instructions supplied with the cover on how to attached if to the male Cat5e network cable.

ENSURE THAT THE IP68 RATED COVER IS CORRECTLY FITTED AND ATTACHED TO THE NETWORK CABLE. IF THIS IS NOT FITTED CORRECTLY MOISTURE CAN GET INTO THE CONNECTOR AND MAY CAUSE THE UNIT TO MALFUNCTION. THIS WOULD VOID THE WARRANTY ON THE PRODUCT.

## Trouble Shooting

Ensure all tests are undertaken by a qualified, trained engineer and ensure safe working practices are followed at all times.

### Step 1: Basics

- Check power connection
- Ensure power is 12-32V DC / 24V AC 50-60Hz
- Check the photocell is working - cover photocell, light should turn on
- Ensure power supply is suitably rated to product - check the specifications

### Step 2: Lamp Test

- Check current draw of lamp corresponds to specification
- Check current of lamp - see instructions for correct current settings

To check lamp current remove +ve (red) lead from power supply and connect a multimeter (set to 10A) in line with the lamp. (One lead of multimeter in common (COM) other lead into 10A socket of multimeter; set multimeter to read Amps). Refer to PSI Specifications for correct current settings.

### Step 3: Set up Camera, lens and Illumination

- Check alignment of lamp
- Check camera lens- fully open at night and set correctly
- Check model number to performance specification to ensure required distance is achievable

### Step 4: Call for further assistance

If the lamp is still not delivering the required performance, please contact Technical Support for further assistance

### Note down:

- Model number and serial number of illuminator
- Camera make and model
- Lens make and model